



H20 TWO

User Manual

©2024 ADJ Products, LLC all rights reserved. Information, specifications, diagrams, images, and instructions herein are subject to change without notice. ADJ Products, LLC logo and identifying product names and numbers herein are trademarks of ADJ Products, LLC. Copyright protection claimed includes all forms and matters of copyrightable materials and information now allowed by statutory or judicial law or hereinafter granted. Product names used in this document may be trademarks or registered trademarks of their respective companies and are hereby acknowledged. All non-ADJ Products, LLC brands and product names are trademarks or registered trademarks of their respective companies.

ADJ Products, LLC and all affiliated companies hereby disclaim any and all liabilities for property, equipment, building, and electrical damages, injuries to any persons, and direct or indirect economic loss associated with the use or reliance of any information contained within this document, and/or as a result of the improper, unsafe, insufficient and negligent assembly, installation, rigging, and operation of this product.

Europe Energy Saving Notice

Energy Saving Matters (EuP 2009/125/EC)

Saving electric energy is a key to help protecting the environment. Please turn off all electrical products when they are not in use. To avoid power consumption in idle mode, disconnect all electrical equipment from power when not in use. Thank you!

DOCUMENT VERSION



Due to additional product features and/or enhancements, an updated version of this document may be available online.

Please check www.adj.com for the latest revision/update of this manual before beginning installation and/or programming.

Date	Document Version	Software Version	DMX Channels	Notes
04/24/2024	1.0	V1.00	4 / 9 Ch.	Initial release
07/29/2024	1.1	N/C	No change	Updated Specifications; added FCC Statement

CONTENTS

Introduction	4
Limited Warranty (USA Only)	5
Warranty Registration Features	6
Safety Precautions	7
Overview	8
Installation Guidelines	9
Lens Replacement	12
Control Panel	13
System Menu	14
UC IR Remote	16
DMX Set Up	17
DMX Traits	19
Color Macros	21
Dimmer Modes and Curves	22
Primary-Secondary Set Up Multi Unit Power Linking	23
Maintenance Guidelines	24
Dimensional Drawings	25
Specifications	26
FCC Statement	27

INTRODUCTION

Unpacking: Thank you for purchasing the H2O Two by ADJ Products, LLC. Every device has been thoroughly tested and has been shipped in perfect operating condition. Carefully check the shipping carton for damage that may have occurred during shipping. If the carton appears to have been damaged, carefully inspect your fixture for any damage and be sure all accessories necessary to operate the unit have arrived intact. In the event that damage has been found or parts are missing, please contact our toll free customer support number for further instructions. Do not return this unit to your dealer without first contacting customer support.

Introduction: Experience the mesmerizing simulated water effect of the ADJ H2O TWO lighting fixture. With a bright 120-Watt LED and 5 Dichroic colors, this versatile fixture is perfect for projecting onto walls, ceilings, or floors, and can be used with or without fog. Its compact design and easy installation make it ideal for creating stunning lighting displays at any event or performance. **This product is intended to be used by professionally trained personnel only and is not suitable for private use.**

Customer Support: Contact ADJ Service for any product related service and support needs. Also visit forums.adj.com with questions, comments or suggestions.

Parts: To purchase parts online visit:

<http://parts.adj.com> (US)

<http://www.adjparts.eu> (EU)

ADJ SERVICE USA - Monday - Friday 8:00am to 4:30pm PST

Voice: 800-322-6337 | support@adj.com

ADJ SERVICE EUROPE - Monday - Friday 08:30 to 17:00 CET

Voice: +31 45 546 85 60 | Fax: +31 45 546 85 96 | support@adj.eu

ADJ PRODUCTS LLC USA

6122 S. Eastern Ave. Los Angeles, CA. 90040

323-582-2650 | Fax 323-532-2941 | www.adj.com | info@adj.com

ADJ SUPPLY Europe B.V

Junostraat 2 6468 EW Kerkrade, The Netherlands

+31 (0)45 546 85 00 | Fax +31 45 546 85 99

www.adj.eu | info@adj.eu

ADJ PRODUCTS GROUP Mexico

AV Santa Ana 30 Parque Industrial Lerma, Lerma, Mexico 52000

+52 (728) 282-7070

For software updates, please contact the service department.

WARNING! This unit is intended for indoor use only! Do not expose to rain or moisture!

CAUTION! There are no user serviceable parts inside this unit. Do not attempt any repairs yourself, as doing so will void your manufacturer's warranty. In the unlikely event your unit may require service, please contact ADJ Products, LLC.

Do not discard the shipping carton in the trash. Please recycle when ever possible.

LIMITED WARRANTY (USA ONLY)

- A. ADJ Products, LLC hereby warrants, to the original purchaser, ADJ Products, LLC products to be free of manufacturing defects in material and workmanship for a prescribed period from the date of purchase (see specific warranty period on reverse). This warranty shall be valid only if the product is purchased within the United States of America, including possessions and territories. It is the owner's responsibility to establish the date and place of purchase by acceptable evidence, at the time service is sought.
- B. For warranty service, you must obtain a Return Authorization number (RA#) before sending the product back—please contact ADJ Products, LLC Service Department at 800-322-6337. Send the product only to the ADJ Products, LLC factory. All shipping charges must be prepaid. If the requested repairs or service (including parts replacement) are within the terms of this warranty, ADJ Products, LLC will pay return shipping charges only to a designated point within the United States. If the entire instrument is sent, it must be shipped in its original package and packaging material. No accessories should be shipped with the product. If any accessories are shipped with the product, ADJ Products, LLC shall incur no liability whatsoever for loss of or damage to any such accessories, nor for the safe return thereof.
- C. This warranty is void if the product serial number and/or labels are altered or removed; if the product is modified in any manner which ADJ Products, LLC concludes, after inspection, affects the reliability of the product; if the product has been repaired or serviced by anyone other than the ADJ Products, LLC factory unless prior written authorization was issued to purchaser by ADJ Products, LLC; if the product is damaged because it was not properly maintained as set forth in the product instructions, guidelines and/or user manual.
- D. This is not a service contract, and this warranty does not include maintenance, cleaning, or periodic check-up. During the period specified above, ADJ Products, LLC will replace defective parts at its expense with new or refurbished parts, and will absorb all expenses for warranty service and repair labor by reason of defects in material or workmanship. The sole responsibility of ADJ Products, LLC under this warranty shall be limited to the repair of the product, or replacement thereof, including parts, at the sole discretion of ADJ Products, LLC. All products covered by this warranty were manufactured after August 15, 2012, and bear identifying marks to that effect.
- E. ADJ Products, LLC reserves the right to make changes in design and/or improvements upon its products without any obligation to include these changes in any products theretofore manufactured.
- F. No warranty, whether expressed or implied, is given or made with respect to any accessory supplied with products described above. Except to the extent prohibited by applicable law, all implied warranties made by ADJ Products, LLC in connection with this product, including warranties of merchantability or fitness, are limited in duration to the warranty period set forth above. And all warranties, whether expressed or implied, including warranties of merchantability or fitness, are limited in duration to the warranty period set forth above. The consumer's and/or dealer's sole remedy shall be such repair or replacement as is expressly provided above; and under no circumstances shall ADJ Product, LLC be liable for any loss and/or damage, direct and/or consequential arising out of the use of, and/or inability to use this product.
- G. This warranty is the only written warranty applicable to ADJ Products, LLC products, and supersedes all prior warranties and written descriptions of warranty terms and conditions heretofore published.

MANUFACTURER'S LIMITED WARRANTY PERIODS:

- Non-LED Lighting Products = 1-Year (365 Days) (Including Special Effect Lighting, Intelligent Lighting, UV lighting, Strobes, Fog Machines, Bubble Machines, Mirror Balls, Par Cans, Trussing, Lighting Stands, Power/Data Distribution, etc. excluding LED and lamps)
- Laser Products = 1-Year (365 Days) (excluding laser diodes which have a 6-Month Limited Warranty)
- LED Products = 2-Year (730 Days) (excluding batteries which have a 180 Day Limited Warranty)
- NOTE: 2-Year (730 Days) Limited Warranty ONLY applies to product purchased within the United States. StarTec Series = 1-Year (365 Days) (excluding batteries which have a 180 Day Limited Warranty)
- ADJ DMX Controllers = 2 Year (730 Days)
- American Audio Products = 1 Year (365 Days)

WARRANTY REGISTRATION

Please fill out the enclosed warranty card to validate your purchase. All returned service items, whether under warranty or not, must be freight pre-paid and accompanied by a return authorization (R.A.) number. The R.A. number must be clearly written on the outside of the return package. A brief description of the problem as well as the R.A. number must also be written down on a piece of paper included in the shipping carton. If the unit is under warranty, you must provide a copy of your proof of purchase invoice. You may obtain an R.A. number by contacting our customer support team. All packages returned to the service department not displaying an R.A. number on the outside of the package will be returned to the shipper.

FEATURES

- Color Wheel with 5 Dichroic Colors Plus White
- 37° and Optional 27° Manually Adjustable Focus
- Manual Focus of Lens for Blurry Effects
- 0.6Hz to 7.5Hz Strobe Rate
- 3 Built-In Programs
- Primary / Secondary Mode
- Fan Cooled

INCLUDED ITEMS

- 1x 6ft (1.83m), 3x18AWG, Indoor Power locking to Edison power cable (U.S.)
- 1x UC-IR (IR Remote)

SAFETY PRECAUTIONS



PROTECTION CLASS 1 - FIXTURE MUST BE PROPERLY GROUNDED.



THERE ARE NO USER SERVICEABLE PARTS INSIDE THIS UNIT. DO NOT ATTEMPT ANY REPAIRS YOURSELF, AS DOING SO WILL VOID YOUR MANUFACTURER'S WARRANTY. DAMAGES RESULTING FROM MODIFICATIONS TO THIS FIXTURE AND/OR THE DISREGARD OF SAFETY INSTRUCTIONS AND GUIDELINES IN THIS MANUAL VOID THE MANUFACTURER'S WARRANTY AND ARE NOT SUBJECT TO ANY WARRANTY CLAIMS AND/OR REPAIRS.



**NEVER LOOK DIRECTLY INTO THE LIGHT SOURCE!
RETINA INJURY RISK - MAY INDUCE BLINDNESS!
SENSITIVE PERSONS MAY SUFFER AN EPILEPTIC SHOCK!**

- ***Ambient operating temperature range is -4°F to 113°F (-20°C to 45°C)!***
- DO NOT TOUCH the fixture housing during operation. Disconnect the power and allow approximately 15 minutes for the fixture to cool down before servicing.
- DO NOT shake the fixture, and avoid brute force when installing and/or operating the fixture.
- DO NOT operate the fixture if the power cord has become frayed, crimped and/or damaged. If the power cord is damaged, replace immediately with a new one of the same power rating.
- DO NOT attempt to remove or break off the ground prong from the electrical cord. This prong is used to reduce the risk of electrical shock and fire in case of an internal short.
- DO NOT attempt to operate this unit if it has been damaged in any way.
- Disconnect from main power before making any type of connection.
- DO NOT block any air ventilation slots. All fan and air inlets must remain clean and never blocked. Allow approx. 6" (15cm) between fixture and other devices or a wall for proper cooling.
- Always be sure to mount this unit in an area that will allow proper ventilation. Allow about 6" (15cm) between this device and a wall.
- DO NOT remove the cover for any reason.
- When installing fixture in a suspended environment, always use mounting hardware that is no less than M10 x 25mm, and always install fixture with an appropriately rated safety cable.
- Never plug this unit in to a dimmer pack.
- During long periods of non-use, disconnect the unit's main power.
- Always mount this unit in safe and stable matter.
- Power-supply cords should be routed so that they are not likely to be walked on or pinched by items placed upon or against them, paying particular attention to the point where they exit from the unit.
- Cleaning - The fixture should be cleaned only as recommended by the manufacturer.
- Heat - The appliance should be situated away from heat sources such as radiators, heat registers, stoves, or other appliances (including amplifiers) that produce heat.
- The fixture should be serviced by qualified service personnel when:
 - A. The power-supply cord or the plug have been damaged.
 - B. Objects have fallen onto, or liquids have been spilled into, the fixture.
 - C. The fixture does not appear to operate normally or exhibits a marked change in performance.
 - D. The fixture has fallen and/or has been subjected to extreme handling.

OVERVIEW

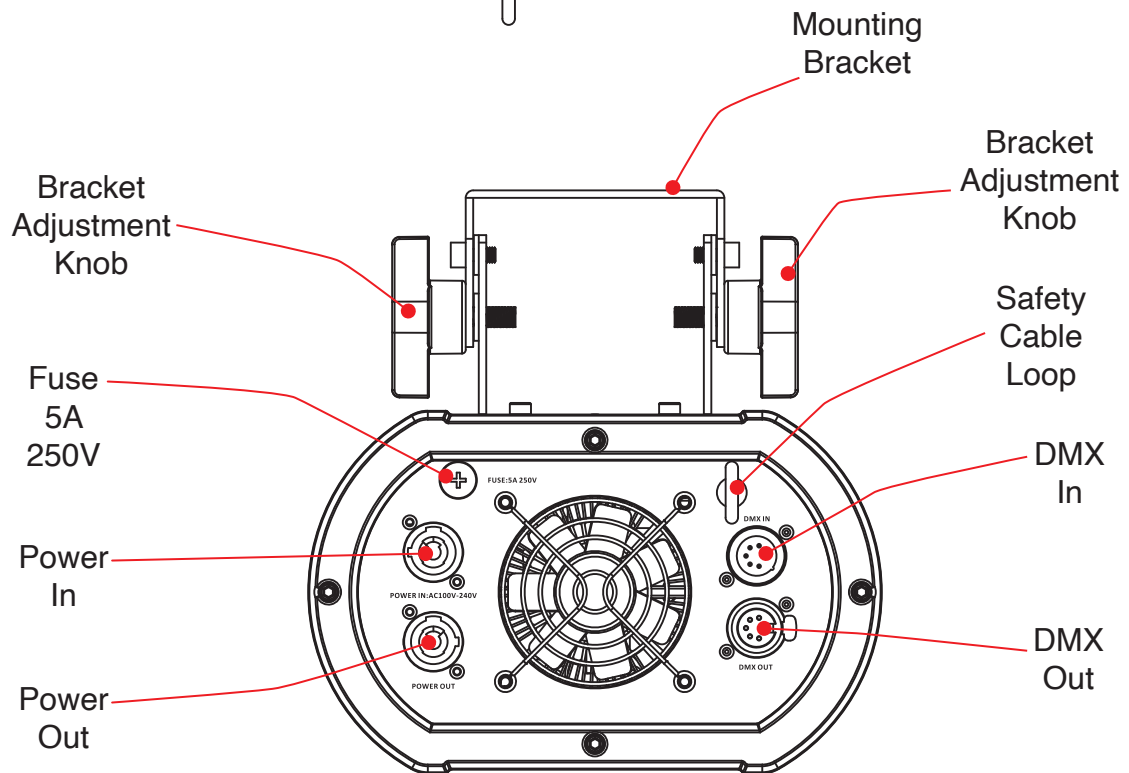
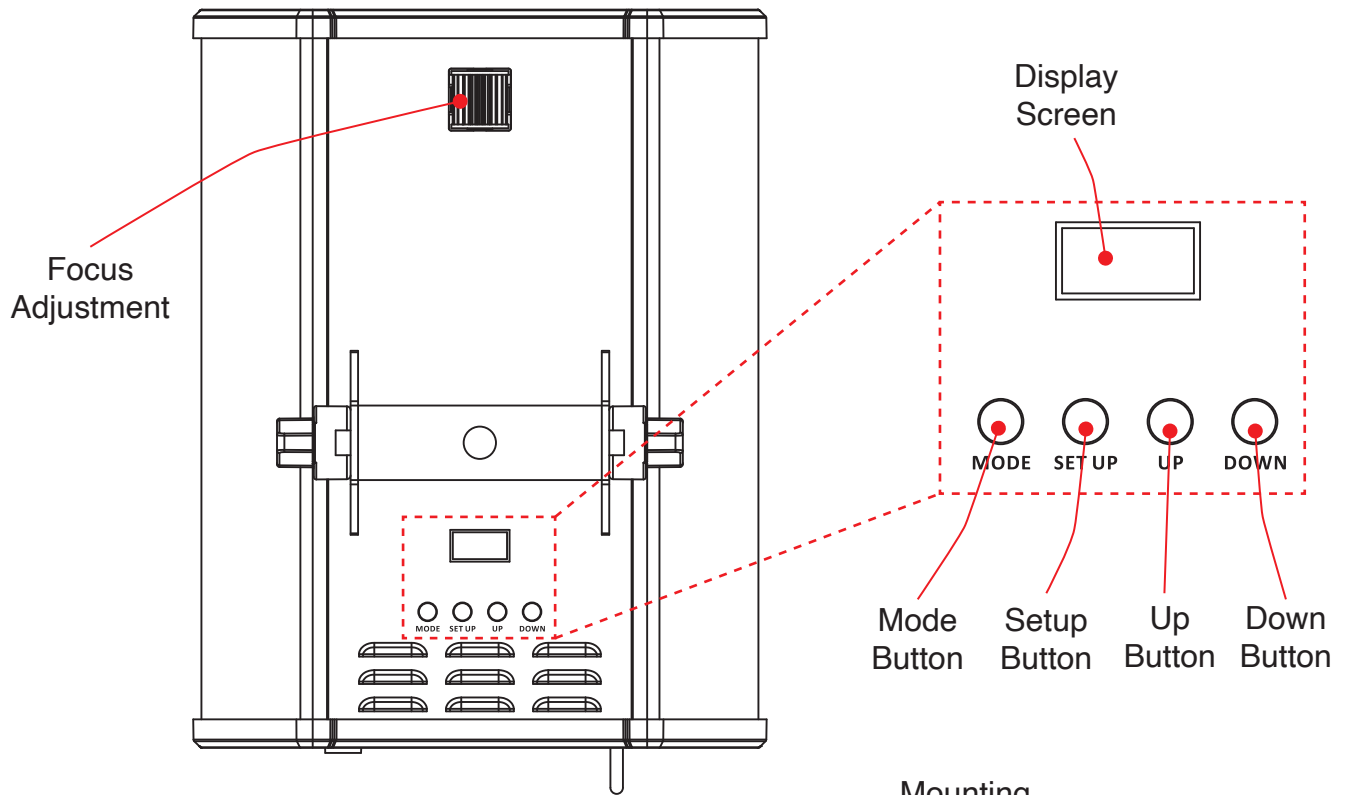

INSTALLATION GUIDELINES



DO NOT INSTALL THE FIXTURE IF YOU ARE NOT QUALIFIED TO DO SO!

Fixture **MUST** be installed following all local, national, and country commercial electrical and construction codes and regulations.

When installing the unit, the trussing or area of installation must be able to hold 10 times the weight of the unit and any attached accessories without any deformation. The unit must be secured with a secondary safety attachment, e.g. an appropriately-rated safety cable.

Before rigging/mounting a single fixture to any metal truss/structure or placing the fixture(s) on any surface, a professional equipment installer **MUST** be consulted to determine if the metal truss/structure or surface is properly certified to safely hold the combined weight of the fixture(s), clamps, cables, and accessories.

Ambient operating temperature range is **-4°F to 113°F (-20°C to 45°C)**. Do not operate this device when ambient temperature falls outside this range!

Fixture(s) should be installed away from walking paths, seating areas, or areas where unauthorized personnel might reach the fixture by hand.

NEVER stand directly below the fixture(s) when rigging, removing, or servicing.

Overhead fixture installation must always be secured with a secondary safety attachment, such as an appropriately rated safety cable that can hold 10 times the weight of the fixture.

Overhead mounting requires extensive experience, including calculating working load limits, knowledge of installation material being used, and periodic safety inspection of all installation material as well as the unit itself. If you lack these qualifications, do not attempt the installation yourself.

The installation should be checked by a skilled person once a year.

INSTALLATION GUIDELINES

CLAMP MOUNTING

When mounting the fixture to a truss or any other suspended structure, be sure to secure an appropriately rated clamp to the hole on the top of each mounting bracket. Insert a bolt of appropriate size through the bottom of the mounting clamp and the hole on the mounting bracket, and secure them together with a matching nut. Additionally, a safety cable of the appropriate weight rating should be secured through the each safety cable loop on the rear panel of the fixture.

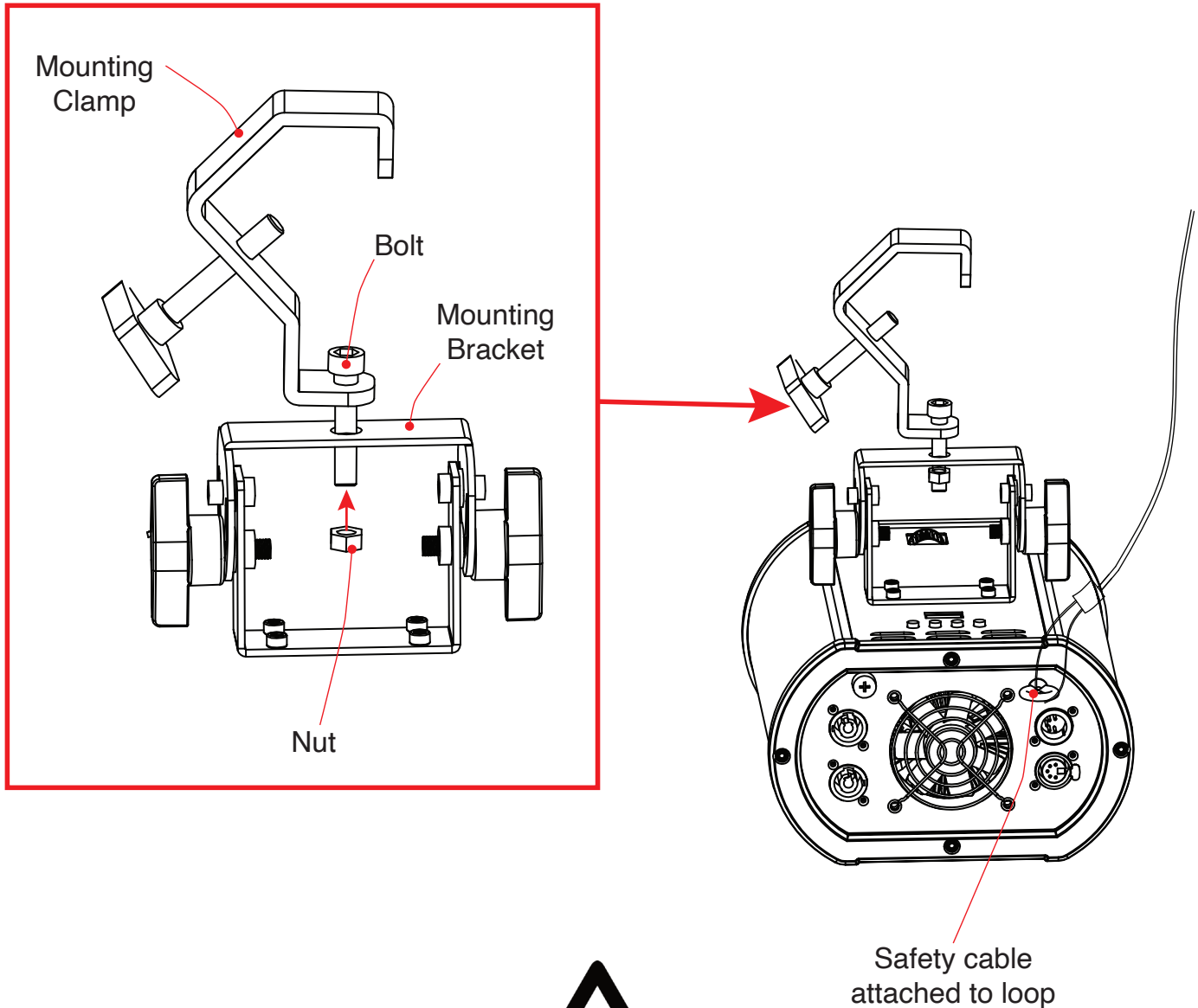

SAFETY CABLE:

ALWAYS ATTACH A SAFETY CABLE WHENEVER INSTALLING THIS FIXTURE IN A SUSPENDED ENVIRONMENT TO ENSURE THAT THE FIXTURE WILL NOT FALL IF THE CLAMP FAILS.

INSTALLATION GUIDELINES

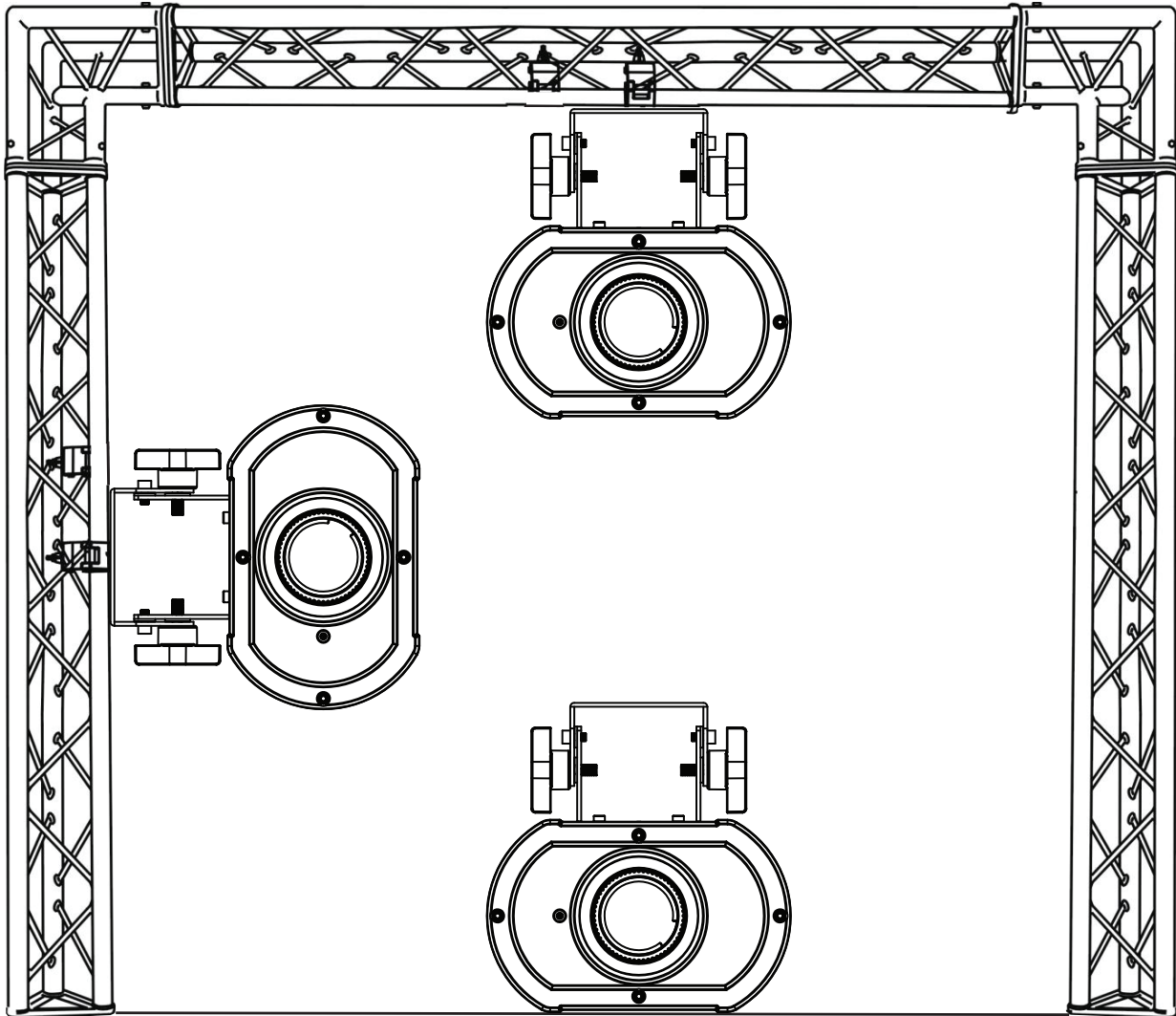

The unit is fully operational in three different mounting positions: hanging upside-down from the ceiling or trussing, sideways on trussing, or set on a flat level surface. Be sure this fixture is kept at least 2m (6.5 ft) away from any flammable materials (decorations, etc). Always use and install a safety cable (not included) as a safety measure to prevent accidental damage and/or injury in the event the clamp fails. Never use the carrying handles for secondary attachment.



FALLING FIXTURES CAN CAUSE SEVERE INJURY OR SERIOUS EQUIPMENT DAMAGE! FOR THIS REASON, FIXTURES SHOULD BE INSTALLED AND INSPECTED ONLY BY QUALIFIED PERSONNEL. DO NOT INSTALL THE UNIT IF YOU LACK THE QUALIFICATIONS TO DO SO, OR IF YOU HAVE DOUBTS ABOUT THE SAFETY AND SECURITY OF THE INSTALLATION SETUP OR LOCATION!



ALWAYS ATTACH A SAFETY CABLE WHENEVER INSTALLING THIS FIXTURE IN A SUSPENDED ENVIRONMENT TO ENSURE THAT THE FIXTURE WILL NOT FALL IF THE CLAMP FAILS.

LENS REPLACEMENT

1. Hold the focus adjustment knob in place. Grip the lens assembly directly and rotate counter-clockwise to unscrew the lens assembly from the main unit.

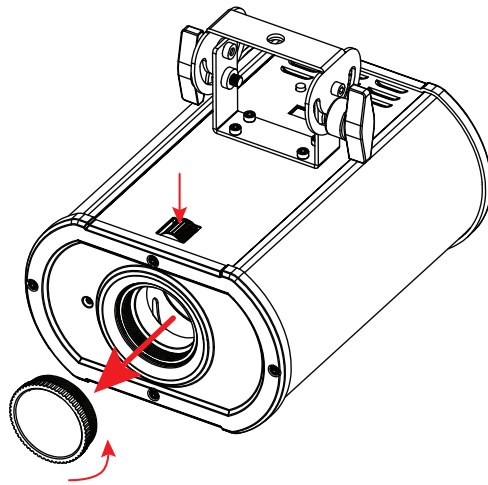

2. Remove the retainer clip from the lens assembly, then remove the lens itself.

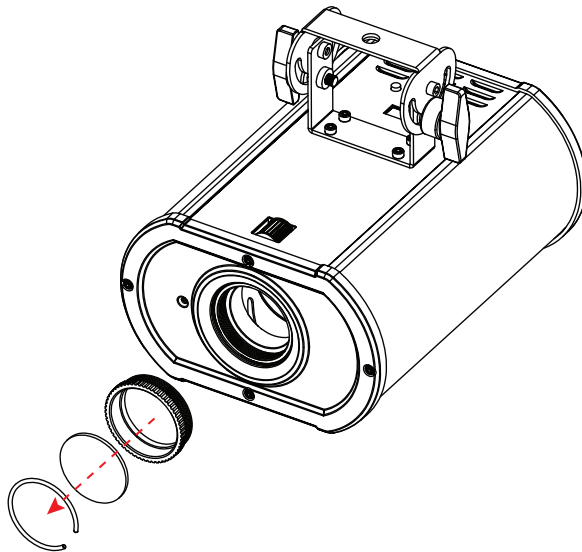

3. Replace the lens and reinstall the retainer clip to secure the lens in place. Reinstall the lens assembly in the unit by inserting the lens assembly back into the front of the unit and rotating the lens assembly clockwise while holding down the focus adjustment knob.

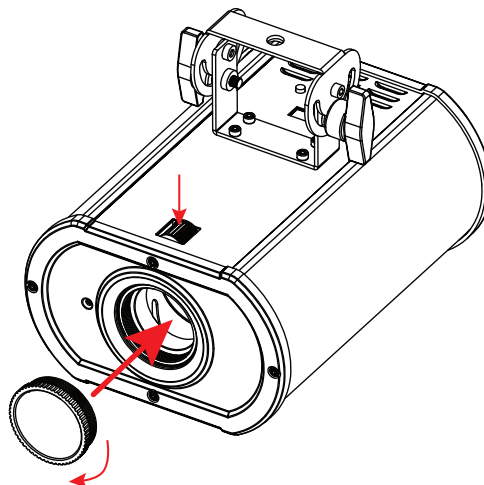

CONTROL PANEL

This unit features a display screen with a 4-button control pad, which can be used to easily adjust any device settings.

Pressing the MODE button will cycle through the various Main Menu options. When the desired Main Menu option is displayed on the screen, press the SETUP button to enter the sub-menu, then use the UP and DOWN buttons to scroll through sub-menu options. In some cases, there will be a second sub-menu that can be navigated in the same way.

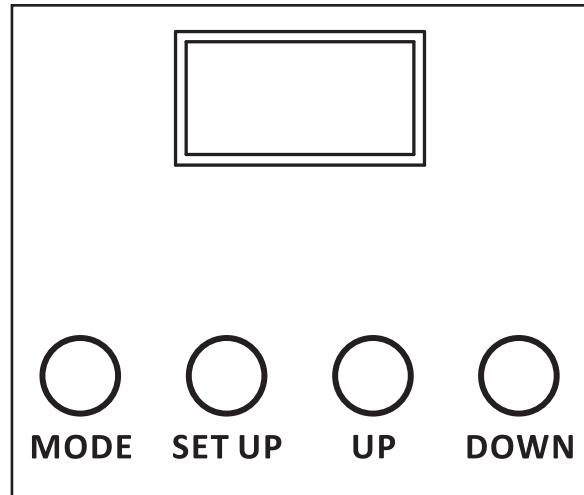

SCREEN LOCK

The control panel screen will lock after a period of inactivity, which is set to 30 seconds by default. This setting can be changed by navigating to Personality > Display > Touch Screen Lock in the system menu. To unlock the screen, press and hold any spot on the display screen until the screen unlocks.

SYSTEM MENU

DMX SET	Address	001 - 512		Set DMX address
	Channel Mode	4Ch / 9Ch		
	No DMX	Hold		Unit holds last settings received if DMX signal is lost
		Blackout		Unit takes all channels to 0 if DMX signal is lost
		Manual		Unit defaults to manual mode if DMX signal is lost
Internal Programs		Unit default to pre selected internal program if DMX signal is lost		
PERSONALITY	Primary / Secondary Mode	Primary / Secondary		Set unit as a primary or secondary unit
	IR Remote	On / Off		Enable or disable IR remote control
	Dim Mode	Standard		Select dim mode
		Stage		
		TV		
		Archi		
		Theatre		
		Stage 2		
		Dim Speed	0.1s - 10s	Set dim speed
	Dim Curve	Linear		Select dim curve
Square				
Inv Squa				
S Curve				

SYSTEM MENU

PERSONALITY (continued)	Display	Save Dlay	1 - 10		Screen goes to sleep after set period of inactivity
		Lock	Off, 30sec , 1 min - 10min		Screen locks after selected period of inactivity
		Rotate Display 180°	Yes		Inverted display orientation
			No		Standard display orientation
			Auto		Display orientation automatically flips as needed to stay upright
	Service	Passcode = 011	Restore	Yes / No	Restore unit to factory default settings
MANUAL	Mastr Dim	000 - 255			Manually configure each unit parameter
	Effect Rotation	000 - 255			
	Color	000 - 255			
INT PROGS	Program 0	Speed	000 - 255		Run set internal program. Speed and fade are adjustable
		Fade	000 - 255		
	Program 1	Speed	000 - 255		
		Fade	000 - 255		
	Program 2	Speed	000 - 255		
		Fade	000 - 255		
Program 3	Speed	000 - 255			
	Fade	000 - 255			
INFO	LED Temperature	xxx °	xxx F / xxx C		Display current LED temperature
	Software Version	x.xx			Display current software version

UC IR REMOTE

This unit can be operated using the ADJ UC IR remote control. **The unit can only be controlled when it has been set to Primary mode. The unit will NOT respond to commands when it has been set to Secondary mode.** When using the UC IR to control multiple units that are operating in primary/secondary mode, follow these steps to set up the units:

1. Power on the unit, and press MODE to scroll to the “Personality” menu, then press SETUP.
2. Use the UP and DOWN buttons to scroll to “Primary/Secondary Mode”. Press SETUP, then use the UP and DOWN buttons set the device to “Primary”. The unit will NOT respond to IR remote commands when it has been set to “Secondary” mode.
3. Press SETUP to confirm and return to the “Personality” menu.
4. Use UP and DOWN to scroll to “IR Remote” and press SETUP.
5. Use the UP and DOWN buttons to scroll to “ON”, then press SETUP to confirm.

CONTROLS

- STAND BY - Press to black out the fixture. Press again to return to the initial state.
- FULL ON - Press to fully illuminate the unit.
- FADE/GOBO - Press to put the unit in Color Fade mode
- “DIMMER +” and “DIMMER -” - Use the buttons to adjust the output intensity when color mode is active.
- STROBE - Press this button for strobing, then use buttons 1 - 4 to select the strobe speed. 1 is the slowest and 4 is the fastest.
- COLOR - Press to put the unit in color mode.
- 1 - 9 BUTTONS - Use to select strobe speed or show mode.
- SOUND ON & OFF - These buttons have no defined function for this unit.
- SHOW 0 - Press this button to select Show mode. Then use buttons 1-3 to select Shows 1-3.



DMX SET UP

DMX-512: DMX is short for Digital Multiplex. This is a universal protocol used as a form of communication between intelligent fixtures and controllers. A DMX controller sends DMX data instructions from the controller to the fixture. DMX data is sent as serial data that travels from fixture to fixture via the DATA “IN” and DATA “OUT” XLR terminals located on all DMX fixtures (most controllers only have a DATA “OUT” terminal).

DMX Linking: DMX is a language allowing all makes and models of different manufacturers to be linked together and operate from a single controller, as long as all fixtures and the controller are DMX compliant. To ensure proper DMX data transmission, try to use the shortest cable path possible when linking several DMX fixtures. The order in which fixtures are connected in a DMX line does not influence the DMX addressing. For example, a fixture assigned a DMX address of 1 may be placed anywhere in a DMX line: at the beginning, at the end, or anywhere in the middle. When a fixture is assigned a DMX address of 1, the DMX controller knows to send DATA assigned to address 1 to that unit, no matter where it is located in the DMX chain.

Data Cable (DMX Cable) Requirements (For DMX Operation): This unit can be controlled via DMX-512 protocol. The DMX address is set on the rear panel of the unit. Your unit and your DMX controller require a standard 5-pin XLR connector for data input and data output. We recommend Accu-Cable DMX cables. If you are making your own cables, be sure to use standard 110-120 Ohm shielded cable (This cable may be purchased at almost all pro lighting stores). Your cables should be made with a male XLR connector at one end and a female XLR connector at the other. Also remember that DMX cable must be daisy chained and cannot be split.

Notice: Be sure to follow the illustration below when making your own cables. Do not use the ground lug on the XLR connector. Do not connect the cable’s shield conductor to the ground lug or allow the shield conductor to come in contact with the XLR’s outer casing. Grounding the shield could cause a short circuit and erratic behavior.

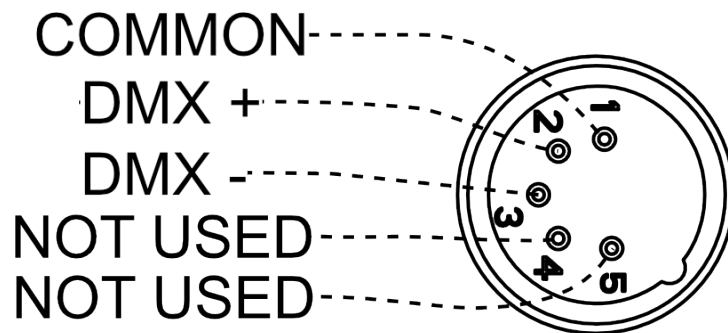

DMX SET UP

Special Note: Line Termination. When longer runs of cable are used, you may need to use a terminator on the last unit to avoid erratic behavior. A terminator is a 110-120 ohm 1/4 watt resistor which is connected between pins 2 and 3 of a male XLR connector (DATA + and DATA -). This unit is inserted in the female XLR connector of the last unit in your daisy chain to terminate the line. Using a cable terminator (ADJ part number Z-DMX/T) will reduce the risk of erratic behavior.

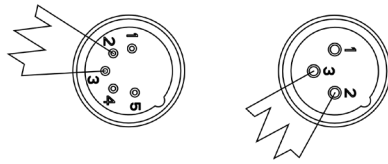

A DMX512 terminator reduces signal errors, avoiding most signal reflection interference. Connect PIN 2 (DMX-) and PIN 3 (DMX+) of the last fixture in series with a 120 Ohm, 1/4 W Resistor to terminate the DMX512.

DMX ADDRESSING.

All fixtures should be given a DMX starting address when using a DMX controller, so the correct fixture responds to the correct control signal. This digital starting address is the channel number from which the fixture starts to “listen” to the digital control signal sent out from the DMX controller. The assignment of this starting DMX address is achieved by setting the correct DMX address on the digital control display on the fixture.

You can set the same starting address for all fixtures or a group of fixtures, or set different addresses for each individual fixture. Setting all fixtures to the same DMX address will cause all fixtures to react in the same way. In other words, changing the settings of one channel will affect all the fixtures simultaneously.

If you set each fixture to a different DMX address, each unit will start to “listen” to the channel number you have set, based on the quantity of DMX channels of each fixture. That means changing the settings of one channel will only affect the selected fixture.

For example, when this unit is operating in 4 channel mode, you should set the starting DMX address of the first unit to 1, the second unit to 5 (1 + 4), the third unit to 9 (1 + 4 + 4), and so on. See the chart below for more details.

CHANNEL MODE	UNIT 1 ADDRESS	UNIT 2 ADDRESS	UNIT 3 ADDRESS	UNIT 4 ADDRESS
4 Ch	1	5	9	13
9 Ch	1	10	19	28

DMX TRAITS

CHANNEL		DMX VALUES	FUNCTION
4Ch	9Ch		
1	1		<i>Dimmer (Intensity)</i>
		0 - 255	Intensity 0 to 100%
2	2		<i>Rotation</i>
		0 - 9	No Rotation
		10 - 120	Clockwise Rotation, fast to slow
		121 - 134	No Rotation
		135 - 245	Counter Clockwise Rotation, slow to fast
		246 - 255	No Rotation
3	3		<i>Colors</i>
		0 - 10	White
		11 - 21	White / Orange
		22 - 32	Orange
		33 - 43	Orange / Green
		44 - 54	Green
		55 - 65	Green / Blue
		66 - 76	Blue
		77 - 87	Blue / Yellow
		88 - 98	Yellow
		99 - 109	Yellow / Purple
		110 - 120	Purple
		121 - 127	Purple / White
		128 - 187	Clockwise Rotation, fast to slow
		188 - 196	Stop
197 - 255	Counter Clockwise Rotation, slow to fast		
	4		<i>Shutter, Strobe</i>
		0 - 31	LEDs Off
		32 - 63	LEDs On
		64 - 95	Strobe Effect, slow to fast
		96 - 127	LEDs On
		128 - 159	Pulse Effect in Sequences
		160 - 191	LEDs On
		192 - 223	Random Strobe Effect, slow to fast
224 - 255	LEDs On		
	5		<i>Auto Programs</i>
		0 - 10	Off
		11 - 26	Program 0
		27 - 43	Program 1
		44 - 60	Program 2
		61 - 76	Program 3
		77 - 255	No Function

DMX TRAITS

CHANNEL		DMX VALUES	FUNCTION
4Ch	9Ch		
	6		<i>Auto Programs Speed</i>
		0 - 255	Slow to Fast Speed
	7		<i>Dim Mode</i>
		0 - 20	Default to Unit Setting
		21 - 40	Standard
		41 - 60	Stage
		61 - 80	TV
		81 - 100	Architectural
		101 - 120	Theatre
		121 - 140	Stage 2
			<i>Dim Speed</i>
		141	0.1s
		142	0.2s
		143	0.3s
		144	0.4s
		145	0.5s
		146	0.6s
		147	0.7s
		148	0.8s
		149	0.9s
		150	1.0s
		151	1.5s
		152	2.0s
		153	3.0s
		154	4.0s
	155	5.0s	
	156	6.0s	
	157	7.0s	
	158	8.0s	
	159	9.0s	
	160	10.0s	
	161 - 255	Default to Unit Setting	
	8		<i>Dim Curves</i>
		0 - 20	Square
		21 - 40	Linear
		41 - 60	Inv Squa
		61 - 80	S Curve
		81 - 255	No Function
4	9		<i>Special</i>
		0 - 10	No Function
		11 - 26	Reset All Motors
		27 - 255	No Function

COLOR WHEEL

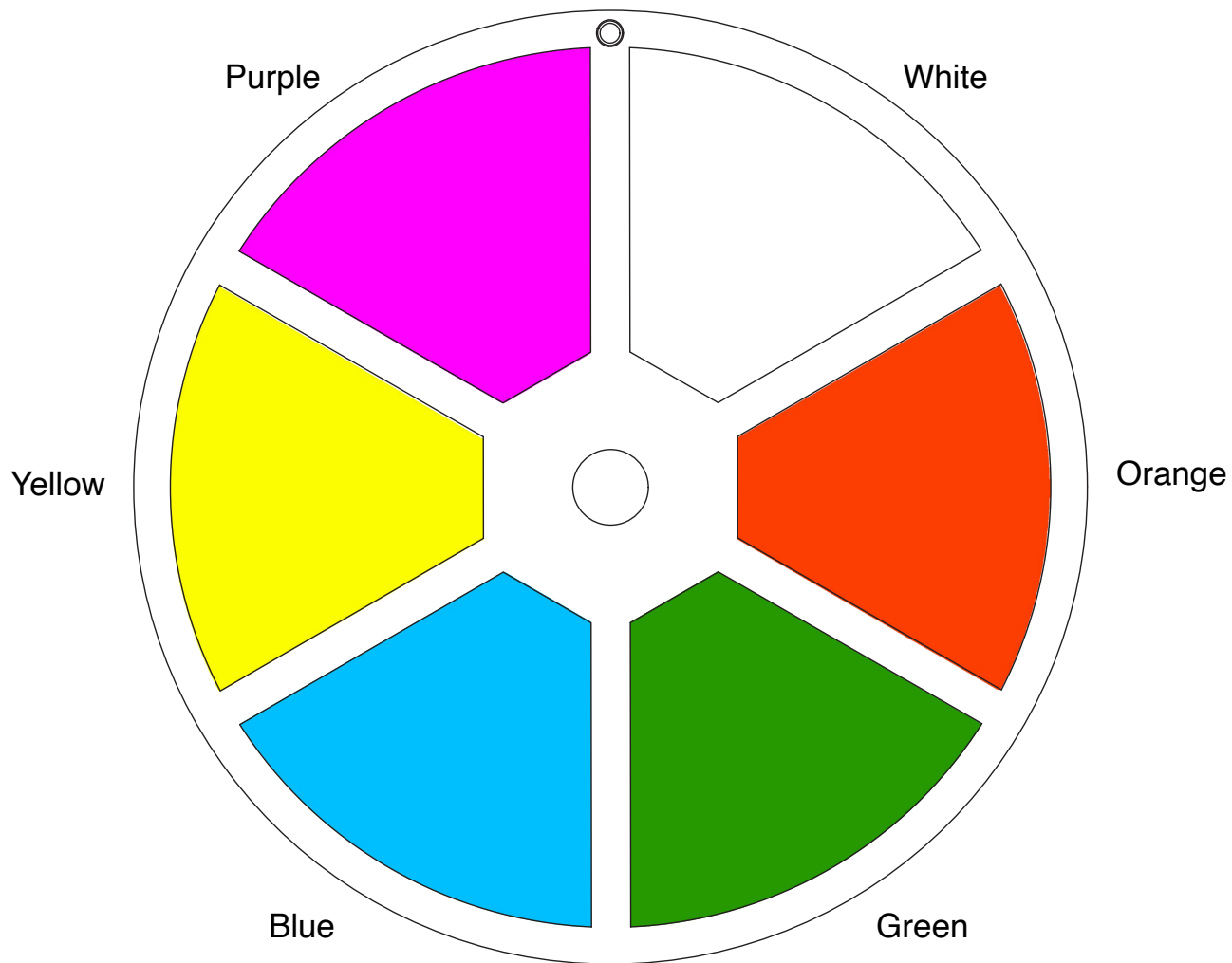

DIMMER MODES AND CURVES

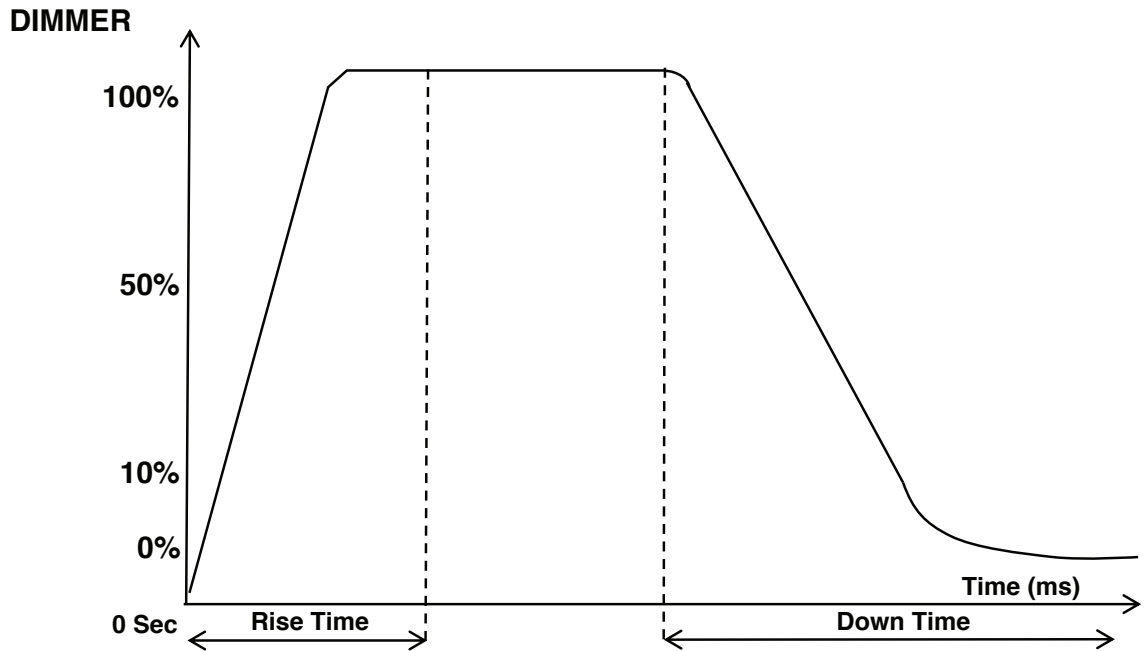

Dimming Curve Ramp Effect	0 sec Fade Time		1 sec Fade Time	
	Rise Time (ms)	Down Time (ms)	Rise Time (ms)	Down Time (ms)
Standard (default)	0	0	0	0
Stage	780	1100	1540	1660
TV	1180	1520	1860	1940
Architectural	1380	1730	2040	2120
Theatre	1580	1940	2230	2280
Stage 2	0	1100	0	1660

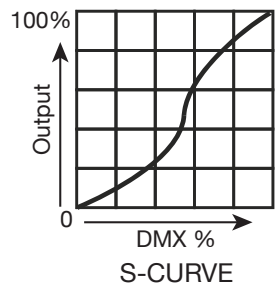
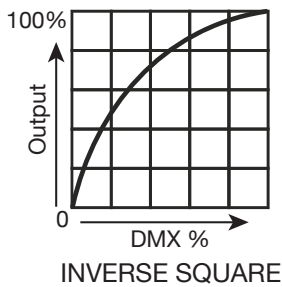
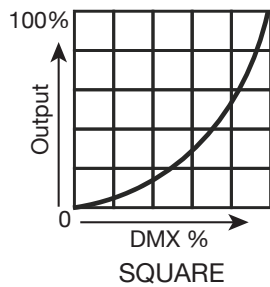
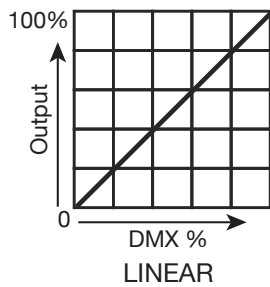

PRIMARY-SECONDARY SET UP

This function allows you to link units together to run in a Primary-Secondary set-up, in which one unit will act as the controlling unit and the others will react to the controlling unit's built-in programs. Any unit can be configured to act as a Primary or as a Secondary, but only one unit in a given system can be programmed to act as the Primary.

Primary-Secondary Connections and Settings:

1. Daisy chain your units via the XLR connectors on the bottom of each unit. Use standard XLR data cables to link your units together. Remember that the male XLR connector is the input and the female XLR connector is the output. The first unit in the chain (primary) will use the female XLR connector only. The last unit in the chain will use the male XLR connector only.
2. On the unit that you want to designate as the primary, use the display screen and control panel to navigate to Personality > Primary/Secondary Mode, then select "Primary" and press the SETUP button to confirm. Configure the operation of the device as desired.
3. On the units that you want to designate as secondaries, use the display screen and control panel to navigate to Personality > Primary/Secondary Mode, then select "Secondary" and press the SETUP button to confirm. The secondary units will now follow the operation of the primary unit.

NOTES:

- Only one unit should be configured as the primary, while all the other units should be configured as secondaries.
- All units should be set to the same DMX channel mode.
- If fixtures fail to sync, verify that all settings mentioned above are the same, then power all devices off, then switch them on again to re-establish the link.

MULTI UNIT POWER LINKING

This feature allows you to connect the fixtures to one another using the power cable input and output sockets.

The maximum number of units that can be linked in this manner is as follows:

- 8 units when running on 120V power.
- 16 units when running on 230V power.

DO NOT EXCEED THIS MAXIMUM NUMBER WHEN POWER LINKING UNITS!

All linked units must be of the same make and model type. Do not mix and match units!

MAINTENANCE GUIDELINES



DISCONNECT POWER BEFORE PERFORMING ANY MAINTENANCE!

CLEANING

Frequent cleaning is recommended to ensure proper function, optimized light output, and an extended life. The frequency of cleaning depends on the environment in which the fixture operates: damp, smoky, or particularly dirty environments can cause greater accumulation of dirt on the fixture's optics. Clean the external lens surface regularly with a soft cloth to avoid dirt/debris accumulation.

NEVER use alcohol, solvents, or ammonia-based cleaners.

MAINTENANCE

Regular inspections are recommended to ensure proper function and extended life. There are no user serviceable parts inside this fixture. Please refer all other service issues to an authorized ADJ service technician. Should you need any spare parts, please order genuine parts from your local ADJ dealer.

Please refer to the following points during routine inspections:

- A. A detailed electrical check by an approved electrical engineer every three months, to make sure the circuit contacts are in good condition and prevent overheating.
- B. Be sure all screws and fasteners are securely tightened at all times. Loose screws may fall out during normal operation, resulting in damage or injury as larger parts could fall.
- C. Check for any deformations on the housing, color lenses, rigging hardware, and rigging points (ceiling, suspension, trussing). Deformations in the housing could allow for dust to enter into the fixture. Damaged rigging points or unsecured rigging could cause the fixture to fall and seriously injure a person(s).
- D. Electric power supply cables must not show any damage, material fatigue, or sediments.

NEVER remove the ground prong from the power cable.

DIMENSIONAL DRAWINGS

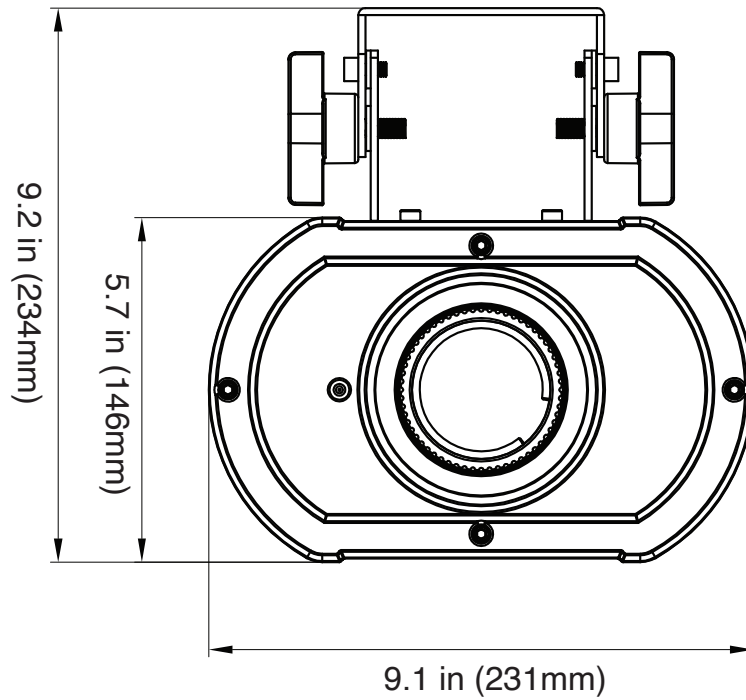
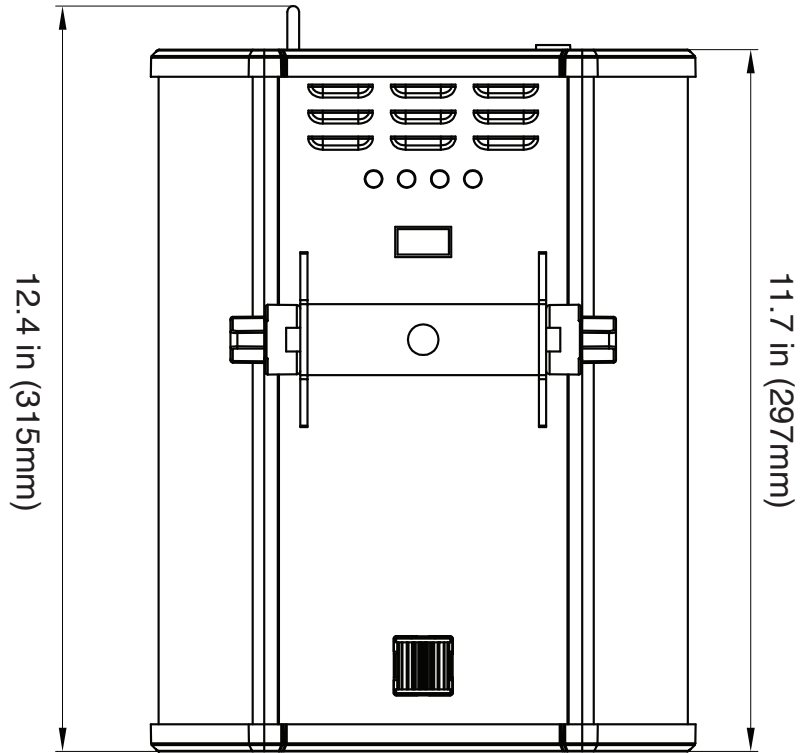

SPECIFICATIONS

Light Source:

- Bright, 120W Cool White LED
- Color Temperature: 7000K
- 50,000 Hour Average LED Life

Features:

- Color Wheel with 5 Dichroic Colors Plus White
- 37° to 27° Manually Adjustable Zoom
- Manual Focus of Lens for Blurry Effects
- 0.6Hz to 7.5Hz Strobe Rate
- 3 Built-In Programs
- Primary / Secondary Mode
- Fan Cooled

Control:

- Control Protocol: DMX and IR Remote
- 2 DMX Modes: 4 and 9 channel modes
- Dim Modes: 6 Presets (Standard, Stage, TV, Architectural, Theatre & Stage 2)
- Dim Curves: 4 Presets (Linear, Square Law, Inv. Square Law and S Curve)
- 0-100% Smooth Dimming
- Variable, Pulse & Random Strobe Modes
- Max Strobe Rate 7.5Hz. Min Strobe Rate: 0.6Hz.
- With Wired Digital Communication Network
- Display: OLED display with 4-button touch menu

Connections:

- Data: IP20 Indoor locking 5-pin DMX In/Out
- Power: IP20 Indoor locking power In/Out
- Safety Loop

Electrical:

- 100-240V 50Hz/60Hz., Auto Sensing, Power Input
- Power Out to link multiple like units
- Max Power Consumption: 128W @120V., 125W @220V.
- Max Power Link: 8pcs @120V., 16pcs @220V.
- Fuse Protected: T5A/250V Glass Fuse (5*20MM)

Dimensions / Weight:

- Length: 12.4" (315mm)
- Width: 9.09" (231mm)
- Height: 9.21" (234mm)
- Weight: 11.02 lbs. (5 kg)

Approvals and Ratings:

- CE
- cETLus (#4002034)
- FCC
- IP20



Please Note: Specifications and improvements in the design of this unit and this manual are subject to change without any prior written notice.

FCC STATEMENT

Please note that changes or modifications to this product that are not expressly approved by the party responsible for compliance could void the user's authority to operate the equipment.

NOTE: This equipment has been tested and found to comply with the limits for a Class A digital device, pursuant to part 15 of the FCC Rules. These limits are designed to provide reasonable protection against harmful interference when the equipment is operated in a commercial environment. This equipment generates, uses, and can radiate radio frequency energy and, if not installed and used in accordance with the instruction manual, may cause harmful interference to radio communications. Operation of this equipment in a residential area is likely to cause harmful interference in which case the user will be required to correct the interference at his own expense.



